



|                    |             |             |
|--------------------|-------------|-------------|
| ITEM # _____       | SIS # _____ | AIA # _____ |
| MODEL # _____      |             |             |
| PROJECT NAME _____ |             |             |

# REACH-IN REFRIGERATORS (2 SECTION)



4-4045



McCall Refrigeration specification sheets are available online @ [www.mccallrefrigeration.com](http://www.mccallrefrigeration.com)

Approval : \_\_\_\_\_

## SPECIFICATIONS

**Cabinet** - Cabinets are all metal, inside and out. The top, back, and bottom are made of galvanized steel. In addition, all seams are closed and sealed, with metal edges turned away from the exposed surface. The result is an integrated structural frame. Internal corners are coved to conform to NSF standards. Automatic interior lighting is controlled by a light switch concealed in the door hinge, except glass door models employ a manual switch.

**Doors** - Constructed of metal, refrigerator doors are self-closing and fully insulated. Their cam-lift hinges are chrome-plated and self-lubricating. Hinges also have a safety stop that holds the door open, preventing overswing. Chrome-plated pull handles have built-in cylinder locks. The full-perimeter, magnetic vinyl gaskets are removable without the use of tools. Doors easily lift off, and door perimeters have a built-in, low wattage, and anti-condensate heater. Door openings are protected by an impact-resistant, nonconduc-

tive PVC breaker strip with no exposed screws or fasteners.

**Insulation** - Cabinet body, doors, and evaporator coil housings are filled with pressure-injected polyurethane foam.

**Interior Shelves** - Three wire shelves per section are standard. Shelves have a runner spaced 3/4 inch O.C. with two reinforcing bars 8 1/2 inch O.C. Coated with 7 mils of baked-on gray epoxy. The shelves have a saline spray corrosion resistance of 600 hours. Shelves will support 250 pounds each with maximum cabinet load of 800 lbs. They are supported on stainless steel pilasters, and are adjustable on 1 inch centers. All three shelves are interchangeable and can be adjusted without tools or special parts.

**Self-Contained Refrigeration** - The complete refrigeration assembly is mounted on top of the cabinet behind a removable hatch cover.

Refrigeration components include a hermetically sealed compressor, thermostatic expansion valve, thermostatic temperature control, high-humidity coated evaporator coil and hot gas condensate evaporator. The system is balanced to maintain 38°F average internal air temperature. Windrunner gradient air displacement process provides even air flow and temperature control throughout the cabinet. All components are factory installed and tested, and supplied with an attached cord and plug (self-contained, 115 volt only less than 16 amps), master power switch, and exterior digital thermometer.

**Remote Cabinets** - Standard remote units are provided with capped refrigeration lines, expansion valve, solenoid valve, electric condensate evaporator, and temperature control. Condensing unit is not included. All other features are the same as self-contained units, except power cord.



# REACH-IN REFRIGERATORS (2 SECTION)

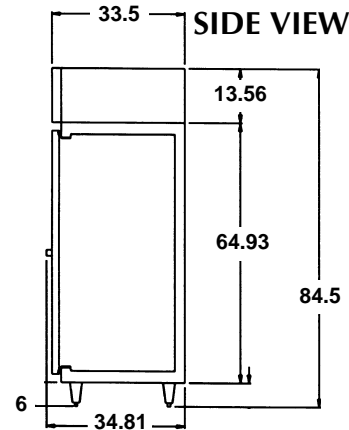
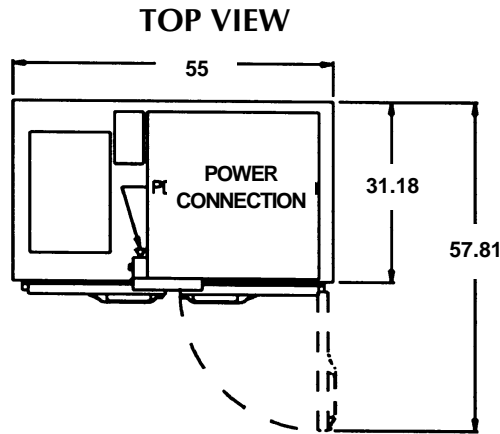

| DIMENSIONS                               |                    |
|--|--------------------|
|  | <b>Two Section</b> |
| Net Capacity:                            | 49 cu.ft.          |
| Width:                                   | 55"                |
| Height: with legs or casters             | 84.5"              |
| Depth: cabinet only - including controls | 31.18"             |
| Depth: over hardware - reach-in          | 34.81"             |
| Depth: door open 90° - reach-in          | 57.81"             |
| Net Door Opening: width                  | 21.25"             |
| Net Door Opening: height -full doors     | 58"                |
| Net Door Opening: height - half doors    | 27"                |
| Adjustable Shelves                       | 6                  |
| Shipping Weight                          |                    |
| Model 1-1045                             | 615 lbs.           |
| 2-2045                                   | 550 lbs.           |
| 4-4045                                   | 500 lbs.           |

| ELECTRICAL             |       |
|------------------------|-------|
| <b>Two Section</b>     |       |
| Base Model Number*     | 45    |
| Compressor HP          | 1/3   |
| Voltage (60 hz, 1 ph)  | 115   |
| Total Amperage:        | 9.2   |
| BTU/HR**               | 2610  |
| Cord connection - ANSI | 5-15P |

**Notes:** (R) Remote cabinets are equipped for 15 amp permanent connection.  
 \*First 3 digits omitted.  
 \*\*Based on 90°F ambient and 20°F evaporating temperature.  
**Specifications subject to change without notice.**  
 Certain options and accessories may affect UL/NSF listing and electrical requirements.

### Bidding Specifications

**McCall Reach In Cabinets shall have:**  
 Top mounted compressor. Automatic defrost. Expansion Valve. Hot gas condensate evaporator. Matched and balanced system. Exclusive Windrunner Gradient Air Displacement Process. Stainless steel front, doors and floor. Self-closing all metal doors with welded and polished corners. Cam-lift hinges with concealed light switches. Adjustable doorstops. Exterior digital thermometer. Chrome-plated door handles with security lock. Stainless steel pilasters adjustable on 1" centers. Three epoxy coated shelves per section. 6" adjustable legs. Master Power Switch. R-134a refrigerant. 49 cubic ft. capacity. Dimensions: Width=55"/Height=84.5"

### OPTIONS

| Model Suffix | Description   | Model Suffix | Description   | Model Suffix | Description  |
|--------------|---|--------------|---|--------------|--|
| 01           | <input type="checkbox"/> Half height doors Qty. _____   | A            | <input type="checkbox"/> Audio visual alarm.  | E            | <input type="checkbox"/> Electric condensate evaporator.   |
| C            | <input type="checkbox"/> Heavy-duty 6 inch casters (on cord connected models only).               | R            | <input type="checkbox"/> Remote.  |              | <input type="checkbox"/> Finished back.                    |
| GD           | <input type="checkbox"/> Glass Doors (See Glass Doors Reach In Refrigerators specification sheet) | X            | <input type="checkbox"/> Sliding glass doors (with vertical 40 watt fluorescent lighting) 2 section only. |              | <input type="checkbox"/> Tray slides _____                 |
|              |   | P            | <input type="checkbox"/> PassThru (see Pass-Thru Refrigerators specification sheet)                       |              | <input type="checkbox"/> Stainless steel shelves.          |
|              |   |              |   |              | <input type="checkbox"/> _____ extra epoxy coated shelves. |
|              |   |              |   |              | <input type="checkbox"/> Left or right door hinge.         |
|              |   |              |   |              | <input type="checkbox"/>                                   |